

Panel-Mount Viewer for the Checker® 200 Series

SensorView 350 is a compact, rugged, panel-mount display for the Checker 200 Series inspection sensors. More than just a display, SensorView provides production statistics and a user-definable view of the parts that Checker is inspecting, enabling operators to easily monitor their production process without ever needing to connect to a PC.

See What Checker Sees

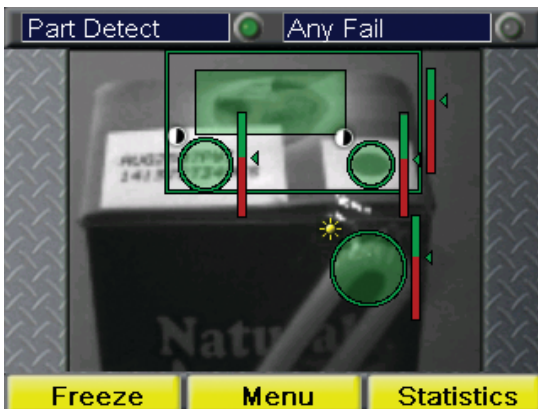

The image screen displays images of inspected parts, with graphics showing the pass/fail status of each Checker sensor.

Control What SensorView Displays

- Select the types of images to be displayed
- Choose the type of inspection images that will automatically freeze the display
- Control the type of images that Checker records in its memory
- Immediately freeze any image for further review



View Production Statistics

Statistics	
Outputs	Count
0 Part Detect	4046240
1 Any Fail	1193
2 Date Code Present	4045986
3 Date Code Missing	254
4 Straw Present	4045301
5 Straw Missing	939

The statistics screen displays the number of parts inspected and real-time statistics for up to eight Checker outputs.

Advantages

- Real-time images with sensor graphics
- User-selectable "image freeze"
- Connects to multiple Checkers (with external USB hub)
- Simple user interface
- Displays images without impacting inspection speed
- 3.5-inch color display

COGNEX

SensorView™ 350

Performance Specifications

MODELS SUPPORTED

Checker 201, Checker 202

USER-SELECTABLE LANGUAGES

English, German, Italian, French, Spanish, Japanese,
Chinese (Simplified), Chinese (Traditional), Korean

POWER

Operating voltage +24VDC (22-26VDC)
Power consumption 275mA @ +24VDC

ENVIRONMENTAL

Operating temperature 0°C to 50°C (32°F to 122°)
Operating humidity 0 to 90%, non-condensing
Storage temperature -20°C to 80°C (-4°F to 176°F)
Storage humidity 0 to 90%, non-condensing

ENVIRONMENTAL (cont.)

Shock 80G x 5ms (IEC 68-2-2)
Vibration 10 G (10 to 500 Hz at 100 M/S² / 15mm x 2 h (IEC 68-2-6)
Altitude 4000m
Protection IP65

CERTIFICATION

c CSA us, CE, FCC, RoHS

MODELS

Part number	Description
SV-350-000	SensorView 350 panel-mount display

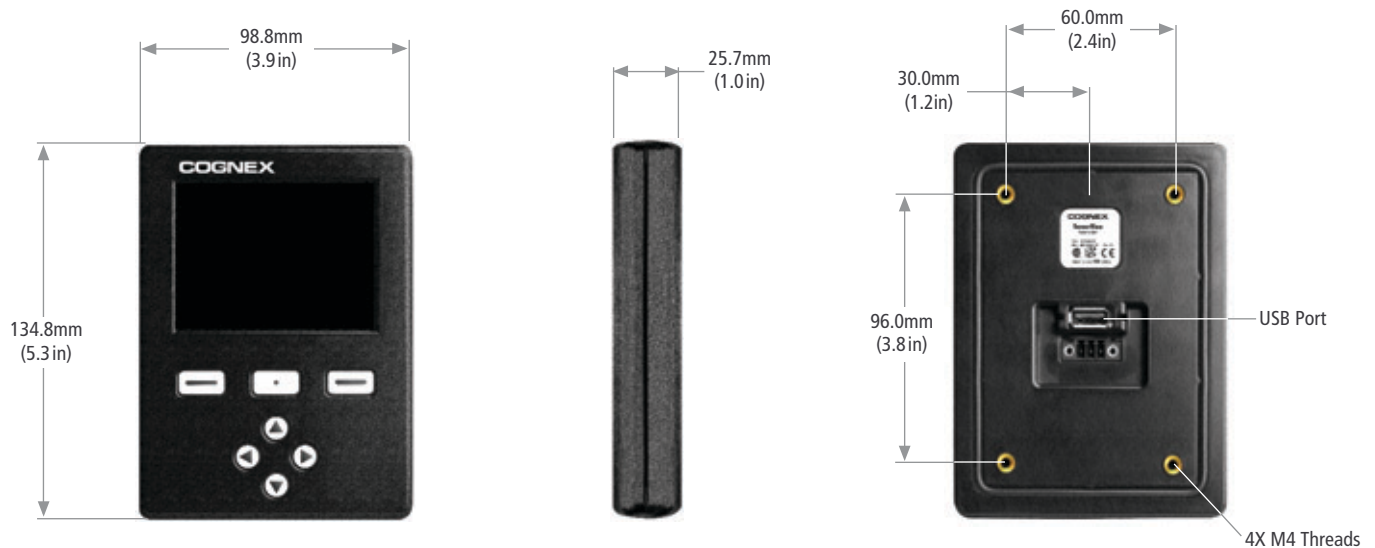

COGNEX

Corporate Headquarters
Cognex Corporation
One Vision Drive
Natick
MA 01760-2059
USA
Tel: 508-650-3000
Fax: 508-650-3344
www.cognex.com

United States
Natick, Massachusetts
Nashville, Tennessee
Detroit, Michigan
Chicago, Illinois
Mountain View, California
Latin America
Monterrey, Mexico
Mexico City, Mexico

www.cognex.com
508-650-3000
615-844-6158
248-668-5100
630-649-6300
650-969-4812
www.cognex.com
+52 81 5030 7258
+52 55 2789 7839

Europe
France
Germany
Ireland
Italy
Netherlands
Spain
Sweden
Switzerland
United Kingdom

www.cognex.net
+33 1 4777 1550
+49 721 6639 0
+353 1 825 4420
+39 02 6747 1200
+31 402 668 565
+34 93 445 67 78
+46 21 14 55 88
+41 71 313 06 05
+44 1908 206 000

Canada www.cognex.com
905-634-2726
Japan www.cognex.co.jp
+81 3 5977 5400
www.cognex.net
Asia
China +86 21 6361 6767
Korea +82 2 539 9047
Singapore +65 632 55 700
Taiwan +886 3 578 0060