

Real-time Visual LED Display Board

VE Series

The VE Series visual LED display is an "Andon" system which is an ideal production management tool on the plant floor. The VE Series provides real-time visual feedback from the plant floor to achieve "Kaizen" for a "Visual Factory". The VE Series comes in two sizes, Model VE25-304S in a 25mm digit size and Model VE100-304S in a 100mm digit size.

Simple

Economical

Lean Manufacturing System

Improve Manufacturing Productivity
Reduce Down Time
Eliminate Waste

Easy Set-up



Plan



Pre Scale



Takt Time

Three Terminal Output



Wide Range AC Adaptor (AC100 to 240V)



VE100-304S
3 Row, 4 Digit Type
Digit Size : 100mm



VE-IR
Infrared Remote Control Unit
(Sold Separately)



VE25-304S
3 Row, 4 Digit Type
Digit Size : 25mm



System Configurations

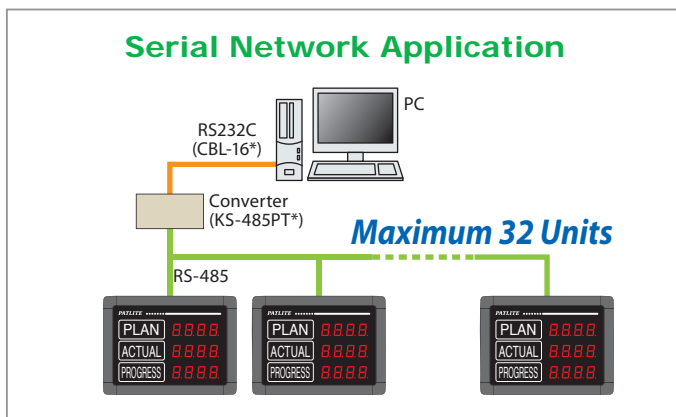

* Refer to the options available



* Refer to the options available (Recommended RS232C (CBL-16) for (KS-485PT))

Dimensions

Model VE25-304S

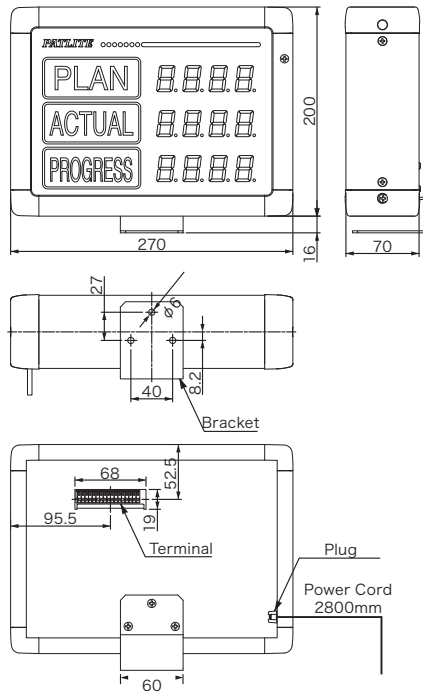

Model VE100-304S

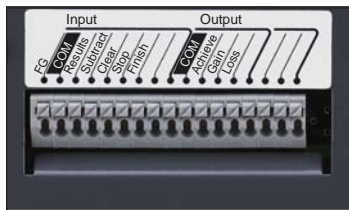
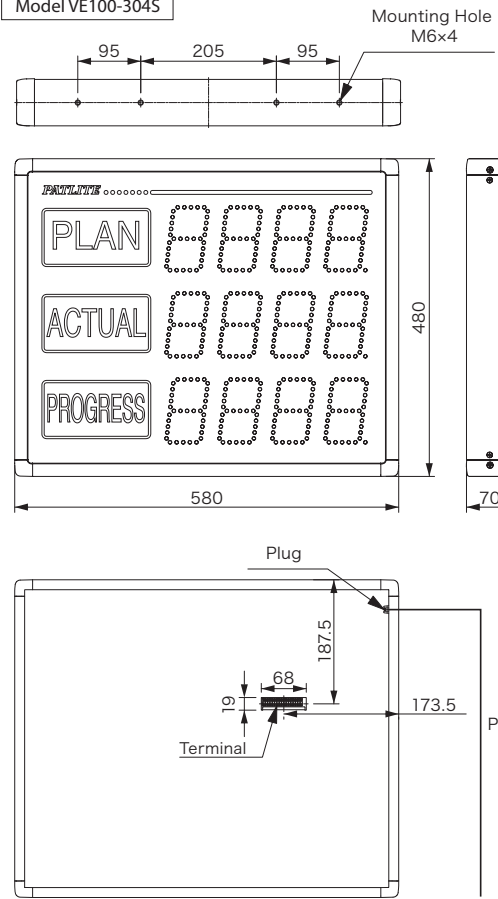

Screwless Terminal - No Tools Required

Cage clamp terminals, just push and release for secure contact. No tools are required.

Unit:mm

Options



Remote Control
Model: VE-IR

For
VE25-304S
VE100-304S



Display Board Label
[Made to Order]

For
VE25-304S
VE100-304S



Brackets (Set of 2)
Model: VE-01

For
VE100



AC Adaptor
Model: VE-AD01

For
VE25
VE100



RS232C/RS485 Converter
Model: KS-485PT

For
VE25-304S
VE100-304S



Connector Cable (1m)
Model: CBL-16

For
VE25-304S
VE100-304S

CAUTION To ensure correct use of these products, read the "Instruction Manual" prior to use. Failure to follow all safeguards can result in fire, electric shock, or other accidents. Specifications are subject to change without notice.

PATLITE Corporation reserves the right to modify product specifications without prior notice within our policy of continual product development.