



DC/DC CONVERTER

- 24V DC-Input
- Isolated 12Vdc Output
- Efficiency up to 88.2%
- Width only 32mm
- 20% Output Power Reserves
- Full Power Between -25°C and +60°C
- Soft-start Function Included
- Minimal Inrush Current Surge
- Reverse Input Polarity Protection
- 3 Year Warranty

GENERAL DESCRIPTION

The Dimension CD-Series offer DIN-rail DC/DC converters in the 92-120W output power range in a very compact housing. These DC/DC converters are allowed to run with a battery or similar sources.

The CD5.121 converts a 24V voltage to a 12V voltage.

The CD5.121 includes all the essential basic functions and has a power reserve of 20% included. This extra power can be used continuously up to +45°C.

The output is electrically isolated from the input in a safe way. The input is protected against reversed voltages and contains a soft start function.

CD-Series

Related products

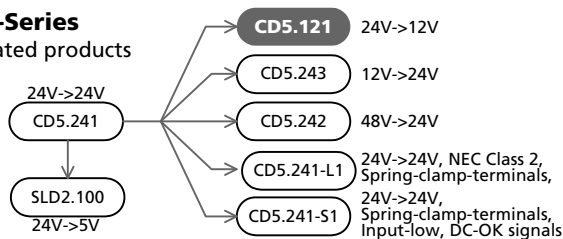

SHORT-FORM DATA

Output voltage	DC 12V	
Adjustment range	12 - 15V	
Output current	8 – 6.4A	ambient <60°C
	9.6 – 7.7A	ambient <45°C
Output power	96W	ambient <60°C
	115W	ambient <45°C
Output ripple	< 75mVpp	20Hz to 20MHz
Input voltage	DC 24V	
Input voltage range	18 to 32.4Vdc	full specified
	14,4 to 18Vdc	with derating
Input current	typ. 4.6A	at 24Vdc input
Input inrush current	typ. 1.2A peak	
Efficiency	88.2%	at 24Vdc input
Losses	12.8W	at 24Vdc input
Temperature range	-25°C to +70°C	operational
Derating	2.5W/°C	+60 to +70°C
Hold-up time	typ. 7ms	at 24Vdc input
Dimensions	32x124x102mm	WxHxD

ORDER NUMBERS

DC/DC Converter	CD5.121	Standard unit
Accessory	ZM1.WALL	Wall mount bracket
	ZM11.SIDE	Side mount bracket

MARKINGS



INDEX

	Page		Page
1. Intended Use	3	19. Fulfilled Standards.....	14
2. Installation Requirements.....	3	20. Physical Dimensions and Weight.....	15
3. Input Voltage	4	21. Accessories	16
4. Soft-start and Input Inrush Current Surge	5	22. Application Notes.....	17
5. Output	6	22.1. Peak Current Capability	17
6. Hold-up Time.....	7	22.2. Back-feeding Loads	17
7. Efficiency and Power Losses.....	8	22.3. Inductive and Capacitive Loads.....	17
8. Functional Diagram.....	9	22.4. Charging of Batteries	18
9. Front Side and User Elements.....	9	22.5. External Input Protection.....	18
10. Terminals and Wiring.....	10	22.6. Requirements for the Supplying Source..	18
11. Reliability.....	10	22.7. Parallel Use to Increase Output Power....	19
12. EMC.....	11	22.8. Parallel Use for Redundancy	19
13. Environment.....	12	22.9. Daisy Chaining of Outputs	20
14. Protection Features	12	22.10. Series Operation	20
15. Safety Features	13	22.11. Use in a Tightly Sealed Enclosure	20
16. Dielectric Strength	13	22.12. Mounting Orientations	21
17. Used Substances	13		
18. Approvals.....	14		

The information presented in this document is believed to be accurate and reliable and may change without notice. Some parts of this unit are patent by PULS (US patent No 091662,063, Des. 424,529, ...).

No part of this document may be reproduced or utilized in any form without permission in writing from PULS GmbH.

TERMINOLOGY AND ABBREVIATIONS

PE and \oplus symbol	PE is the abbreviation for Protective Earth and has the same meaning as the symbol \oplus .
Earth, Ground	This document uses the term "earth" which is the same as the U.S. term "ground".
T.b.d.	To be defined, value or description will follow later.
DC 24V	A figure displayed with the AC or DC before the value represents a nominal voltage with standard tolerances included. E.g.: DC 12V describes a 12V battery disregarding whether it is full (13.7V) or flat (10V)
24Vdc	A figure with the unit (Vac) at the end is a momentary figure without any additional tolerances included.

1. INTENDED USE

This device is designed for installation in an enclosure and is intended for the general use such as in industrial control, office, communication, and instrumentation equipment.

Do not use this DC/DC converter in aircrafts, trains and nuclear equipment where malfunction may cause severe personal injury or threaten human life.

This device is designed for use in hazardous, non-hazardous, ordinary or unclassified locations.

2. INSTALLATION REQUIREMENTS

This device may only be installed and put into operation by qualified personnel.

This device does not contain serviceable parts. The tripping of an internal fuse (if included) is caused by an internal defect.

If damage or malfunction should occur during installation or operation, immediately turn power off and send unit to the factory for inspection.

Mount the unit on a DIN-rail so that the output terminals are located on top and input terminal on the bottom. For other mounting orientations see de-rating requirements in this document.

This device is designed for convection cooling and does not require an external fan. Do not obstruct airflow and do not cover ventilation grid (e.g. cable conduits) by more than 30%!

Keep the following installation clearances: 40mm on top, 20mm on the bottom, 5mm on the left and right sides are recommended when the device is loaded permanently with more than 50% of the rated power. Increase this clearance to 15mm in case the adjacent device is a heat source (e.g. another DC/DC converter).

⚠ WARNING Risk of electrical shock, fire, personal injury or death.

- Do not use the DC/DC-converter without proper grounding (Protective Earth). Use the terminal on the input block for earth connection and not one of the screws on the housing.
- Turn power off before working on the device. Protect against inadvertent re-powering.
- Make sure that the wiring is correct by following all local and national codes.
- Do not modify or repair the unit.
- Do not open the unit as high voltages may present inside.
- Use caution to prevent any foreign objects from entering the housing.
- Do not use in wet locations or in areas where moisture or condensation can be expected.
- Do not touch during power-on, and immediately after power-off. Hot surface may cause burns.

3. INPUT VOLTAGE

Input voltage	nom.	DC 24V	
Input voltage range		18.0-32.4Vdc	full specified
		14.4-18.0Vdc	maximal 60 seconds or with de-rating see Fig. 5 2
	max.	36.0Vdc	absolute maximum continuous input voltage with no damage to the DC/DC converter
Allowed voltage between input and earth	max.	60Vdc or 42.2Vac	in case the output voltage is not grounded.
Allowed input ripple voltage	max.	5Vpp	47Hz-40kHz, the momentary input voltage must always be within the specified limits.
Turn-on voltage	typ.	17.5Vdc	steady-state value, see Fig. 3-1
Shut-down voltage	typ.	14.0Vdc	steady-state value, see Fig. 3-1
	typ.	35.0Vdc	steady-state value, see Fig. 3-1
Input current	typ.	4.6A	at 24Vdc input and output 12V, 8A, see Fig. 5 4
Start-up delay	typ.	420ms	see Fig. 5 3
Rise time	typ.	210ms	0mF, 12V, constant current load 5A, see Fig. 5 3
	typ.	240ms	8mF, 12V, constant current load 5A, see Fig. 5 3
Turn-on overshoot	max.	500mV	see Fig. 5 3
Input capacitance	typ.	3 000µF	external capacitors on the input voltage bus are allowed without any limitations.

Fig. 3-1 Input voltage range

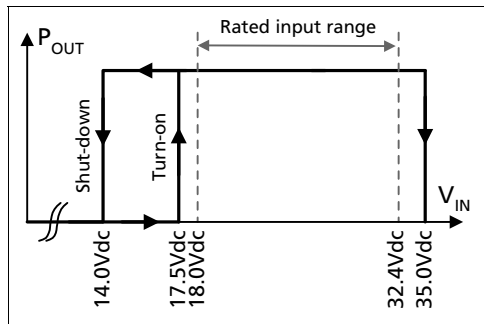

Fig. 3-2 Allowable output current below 18V input voltage

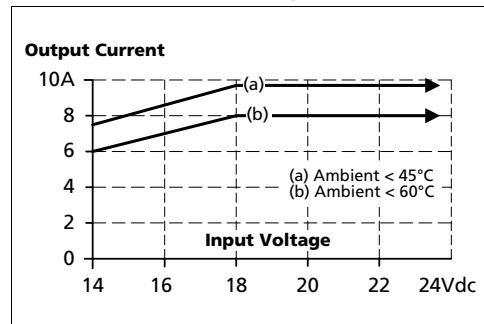

Fig. 3-3 Turn-on behavior, definitions

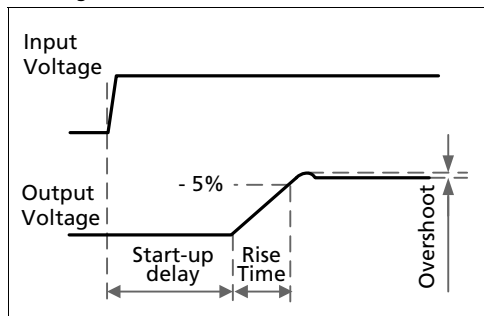
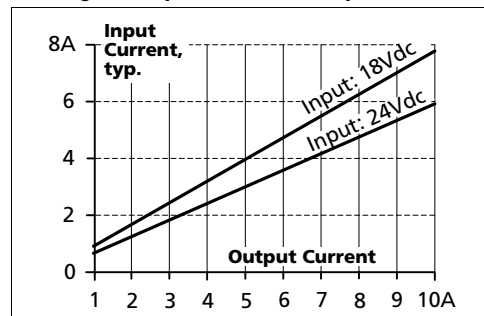

Fig. 3-4 Input current vs. output load



4. SOFT-START AND INPUT INRUSH CURRENT SURGE

Inrush current limitation

An active inrush limitation circuit (inrush limiting resistor which is bypassed by a relay contact) limits the input inrush current after turn-on of the input voltage.

The charging current into EMI suppression capacitors is disregarded in the first microseconds after switch-on.

Inrush current	max.	1.6A _{peak}	-25°C to +70°C, input: 24Vdc
	typ.	1.2A _{peak}	-25°C to +70°C, input: 24Vdc
Inrush energy	typ.	negligible	-25°C to +70°C, input: 24Vdc

Fig. 4-1 Input inrush current, typical behavior

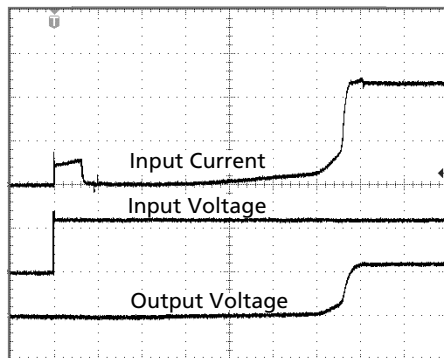

Input: 24Vdc
 Output: 12V, 8A, constant current load
 Ambient: 25°C

Upper curve: Input current 2A / DIV
 Middle curve: Input voltage 20V / DIV
 Lower curve: Output voltage 10V / DIV
 Time basis: 100ms / DIV

Soft-start function:

After the DC/DC converter is turned on, the internal output current rises slowly to its nominal value. This method charges the output capacitors (internal and external capacitors) slowly and avoids high input currents during turn-on. High input currents can produce a high voltage drop on the input wiring (especially with long and thin cables) which reduces the terminal voltage on the DC/DC converter. If the terminal voltage is below the shut-down voltage, the DC/DC converter will turn-off and will make a new start-up attempt. This effect is avoided with the integrated soft-start function. Please note, that this function increases the rise time of the output voltage by a small amount.

Fig. 4-2 Soft-start behavior

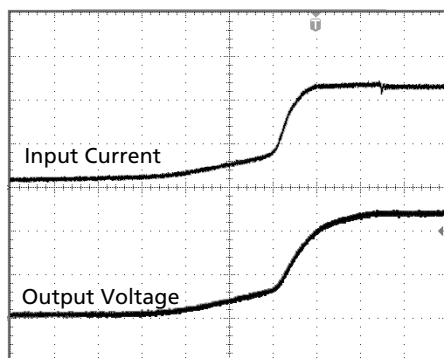

Input: 24Vdc
 Output: 12V, 8A, constant current load
 Ambient: 25°C
 No additional external output capacitors

Upper curve: Input current 2A / DIV
 Lower curve: Output voltage 5V / DIV
 Time basis: 20ms / DIV

5. OUTPUT

Output voltage	nom.	12V	
Adjustment range	min.	12-15V	guaranteed
	max.	16.1V	at clockwise end position of potentiometer
Factory setting		12.0V	±0.2%, at full load, cold unit
Line regulation	max.	25mV	Input voltage variations between 18 to 32.4Vdc
Load regulation	max.	120mV	static value, 0A → 8A
Ripple and noise voltage	max.	75mVpp	20Hz to 20MHz, 50Ohm
Output current	nom.	9.6A	at 12V, ambient < 45°C, see Fig. 5-1
	nom.	8A	at 12V, ambient < 60°C, see Fig. 5-1
	nom.	7.7A	at 15V, ambient < 45°C, see Fig. 5-1
	nom.	6.4A	at 15V, ambient < 60°C, see Fig. 5-1
Output power	nom.	115W	for ambient temperatures < 45°C
	nom.	96W	for ambient temperatures < 60°C
Short-circuit current	min.	14A	continuous current, short circuit impedance 150mOhm
	max.	18A	continuous current, short circuit impedance 150mOhm
Output capacitance	typ.	6 500µF	

Fig. 5-1 Output voltage vs. output current at 24Vdc input voltage, typ.

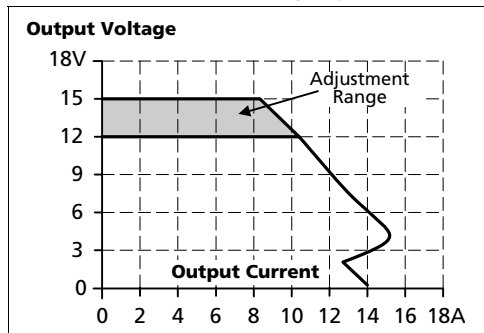
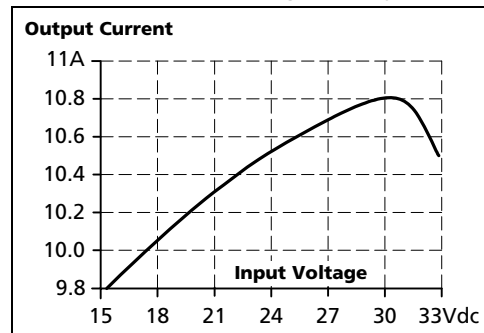

Fig. 5-2 Current limitation vs. input voltage, (11.5V constant voltage load), typ.



Peak current capability (up to several milliseconds)

The DC/DC converter can deliver a peak current, which is higher than the specified short term current. This helps to start current demanding loads or to safely operate subsequent circuit breakers.

The extra current is supplied by the output capacitors inside the DC/DC converter. During this event, the capacitors will be discharged and causes a voltage dip on the output. Detailed curves can be found in chapter 22.1.

Peak current voltage dips	typ.	from 12V to 8.3V	at 16A for 50ms, resistive load
	typ.	from 12V to 6.2V	at 40A for 2ms, resistive load
	typ.	from 12V to 4.3V	at 40A for 5ms, resistive load

6. HOLD-UP TIME

The input side of the DC/DC converter is equipped with a bulk capacitor which keeps the output voltage alive for a certain period of time when the input voltage dips or is removed. The bulk capacitor can be discharged by loading the DC/DC converter on the output side or through a load which is parallel to the input. There is no protection in the DC/DC converter which prevents current from flowing back to the input terminals. If prevention is needed, an external diode should be used.

Hold-up Time	typ.	12.8ms	input 24Vdc, output: 12Vdc, 4A, see Fig. 6-1
	typ.	7ms	input 24Vdc, output: 12Vdc, 8A, see Fig. 6-1

Fig. 6-1 **Hold-up time vs. input voltage**

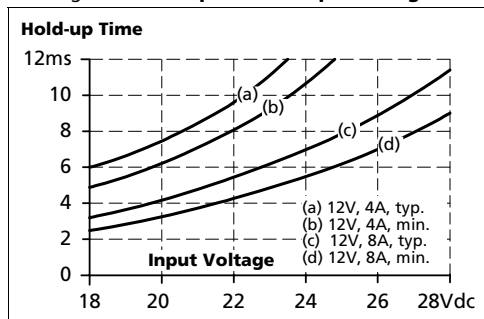

Fig. 6-2 **Shut-down test setup**

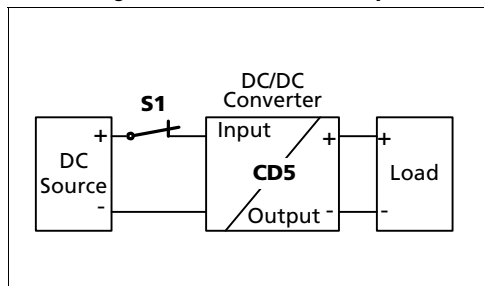
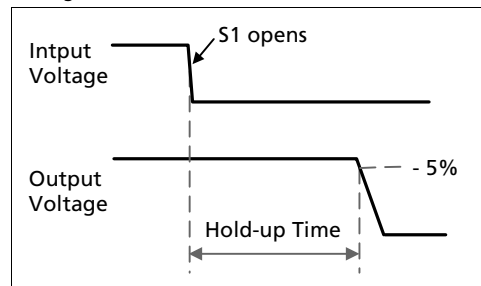

Fig. 6-3 **Shut-down behavior, definitions**



Note: At no load, the hold-up time can be up to several seconds. The green DC-ok lamp is also on during this time.

7. EFFICIENCY AND POWER LOSSES

Input 24Vdc			
Efficiency	typ.	88.2%	at 12V, 8A
Power losses	typ.	0.6W	at no output load
	typ.	6.4W	at 12V, 4A
	typ.	12.8W	at 12V, 8A
	typ.	16.8W	at 12V, 9.6A

Fig. 7-1 Efficiency vs. output current at 12V output and 24Vdc input voltage, typ.

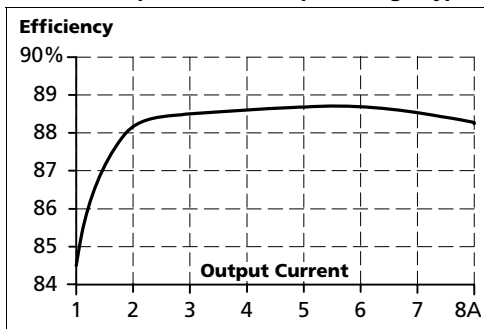

Fig. 7-2 Losses vs. output current at 12V output and 24Vdc input voltage, typ.

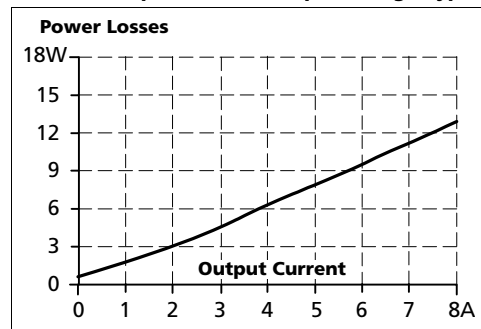

Fig. 7-3 Efficiency vs. input voltage at 12V, 8A, typ.

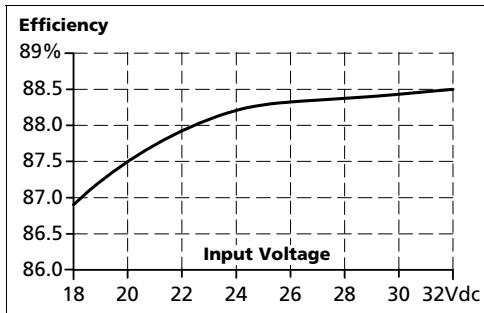
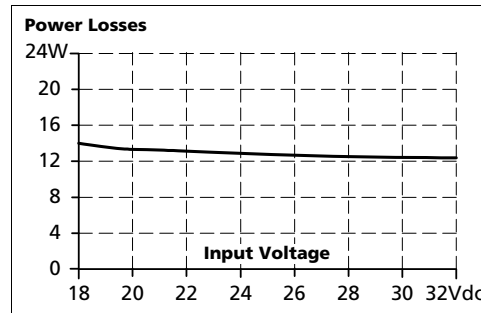
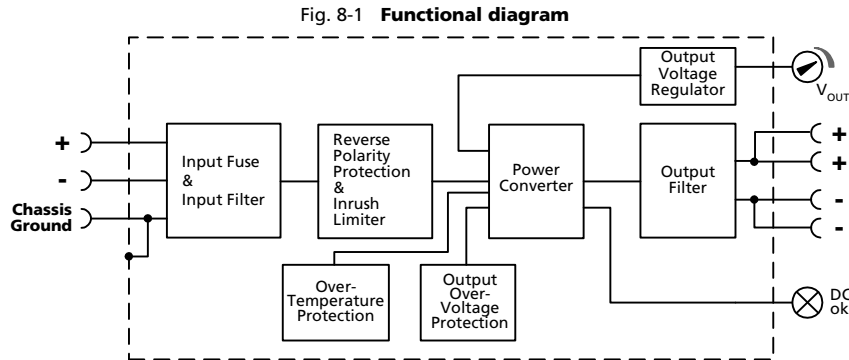

Fig. 7-4 Losses vs. input voltage at 12V, 8A, typ.



8. FUNCTIONAL DIAGRAM



9. FRONT SIDE AND USER ELEMENTS

Fig. 9-1 Front side



- A** Input terminals
Screw terminals
+ Positive input
- Negative (return) input
Chassis ground: can be used to bond the housing to PE
Ground this terminal to minimize high-frequency emissions.
- B** Output terminals
Screw terminals, dual terminals per pole, both pins are equal
+ Positive output
- Negative (return) output Screw terminals
- C** Output voltage potentiometer
Open the flap to set the output voltage. Factory set: 12.0V
- D** DC-OK LED (green)
On when the voltage on the output terminals is > 8.5V

10. TERMINALS AND WIRING

	Input	Output
Type	screw terminals	screw terminals
Solid wire	0.5-6mm ²	0.5-6mm ²
Stranded wire	0.5-4mm ²	0.5-4mm ²
American Wire Gauge	20-10 AWG	20-10 AWG
Wire stripping length	7mm / 0.275inch	7mm / 0.275inch
Screwdriver	3.5mm slotted or Pozidrive No 2	3.5mm slotted or Pozidrive No 2
Recommended tightening torque	1Nm, 9lb.in	1Nm, 9lb.in

Instructions:

- a) Use appropriate copper cables that are designed for an operating temperature of:
60°C for ambient up to 45°C and
75°C for ambient up to 60°C minimum.
- b) Follow national installation codes and installation regulations!
- c) Ensure that all strands of a stranded wire enter the terminal connection!
- d) Up to two stranded wires with the same cross section are permitted in one connection point.
- e) Do not load the terminals with more than 25A! See section 22.9
- f) Screws of unused terminal compartments should be securely tightened.
- g) Ferrules are allowed, but not required

11. RELIABILITY

	Input 24Vdc	
Lifetime expectancy *)	173 000h	at 12V, 4A and 40°C
	63 000h	at 12V, 8A and 40°C
	35 000h	at 12V, 9.6A and 40°C
	179 000h	at 12V, 8A and 25°C
MTBF **) SN 29500, IEC 61709	1 161 000h	at 12V, 8A and 40°C
	1 904 000h	at 12V, 8A and 25°C
MTBF **) MIL HDBK 217F	610 000h	at 12V, 8A and 40°C; Ground Benign GB40
	817 000h	at 12V, 8A and 25°C; Ground Benign GB25

*) The **Lifetime expectancy** shown in the table indicates the minimum operating hours (service life) and is determined by the lifetime expectancy of the built-in electrolytic capacitors. Lifetime expectancy is specified in operational hours and is calculated according to the capacitor's manufacturer specification. The prediction model allows only a calculation of up to 15 years from date of shipment.

) **MTBF stands for **Mean Time Between Failure**, which is calculated according to statistical device failures, and indicates reliability of a device. It is the statistical representation of the likelihood of a unit to fail and does not necessarily represent the life of a product.

12. EMC

The DC/DC converter is suitable for applications in industrial environment as well as in residential, commercial and light industry environment without any restrictions. The CE mark indicates conformance with EMC guideline 89/336/EEC, 93/68/EEC and 2004/108/EC and the low-voltage directive (LVD) 73/23/EWG and 2006/95/EC. A detailed EMC report is available on request.

EMC Immunity		Generic standards: EN 61000-6-1 and EN 61000-6-2		
Electrostatic discharge	EN 61000-4-2	Contact discharge	8kV	Criterion A
		Air discharge	15kV	Criterion A
Electromagnetic RF field	EN 61000-4-3	80MHz-2.7GHz	10V/m	Criterion A
Fast transients (Burst)	EN 61000-4-4	Input lines	4kV	Criterion A
		Output lines	2kV	Criterion A
Surge voltage on input	EN 61000-4-5	+ → -	1kV	Criterion A
		+/- → chassis ground	2kV	Criterion A
Surge voltage on output	EN 61000-4-5	+ → -	500V	Criterion A
		+ / - → chassis ground	500V	Criterion A
Conducted disturbance	EN 61000-4-6	0.15-80MHz	10V	Criterion A

Criteria:

A: DC/DC converter shows normal operation behavior within the defined limits.

C: Temporary loss of function is possible. DC/DC converter may shut-down and restarts by itself. No damage or hazards for the DC/DC converter will occur.

EMC Emission		Generic standards: EN 61000-6-3 and EN 61000-6-4	
Conducted emission	IEC/CISPR 16-1-2, IEC/CISPR 16-2-1	Class B, input lines (Limits for DC power ports)	
Radiated emission	EN 55011, EN 55022	Class B	

This device complies with FCC Part 15 rules.

Operation is subjected to following two conditions: (1) this device may not cause harmful interference, and (2) this device must accept any interference received, including interference that may cause undesired operation.

Switching frequency

Variable between 90kHz and 145kHz depending on load and input voltage (output current > 0.5A)

13. ENVIRONMENT

Operational temperature *)	-25°C to +70°C (-13°F to 158°F)	reduce output power according Fig. 13-1
Storage temperature	-40 to +85°C (-40°F to 185°F)	for storage and transportation
Output de-rating	1.25W/°C 2.5W/°C	45-60°C (113°F to 140°F) 60-70°C (140°F to 158°F)
Humidity **)	5 to 95% r.H.	IEC 60068-2-30
Vibration sinusoidal	2-17.8Hz: ±1.6mm; 17.8-500Hz: 2g 2 hours / axis	IEC 60068-2-6
Shock	30g 6ms, 20g 11ms 3 bumps / direction, 18 bumps in total	IEC 60068-2-27
Altitude	0 to 6000m (0 to 20 000ft)	reduce output power or ambient temperature above 2000m sea level.
Altitude de-rating	6W/1000m or 5°C/1000m	above 2000m (6500ft), see Fig. 13-2
Over-voltage category	III II	IEC 62103, EN 50178, altitudes up to 2000m altitudes from 2000m to 6000m
Degree of pollution	2	IEC 62103, EN 50178, not conductive

*) Operational temperature is the same as the ambient temperature and is defined as the air temperature 2cm below the unit.

***) Do not energize while condensation is present

Fig. 13-1 Output current vs. ambient temp.

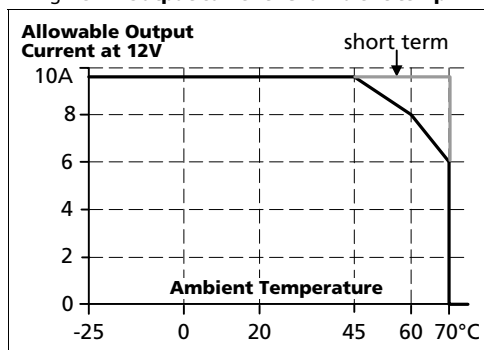
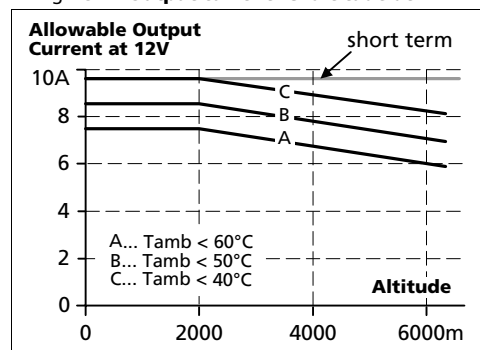

Fig. 13-2 Output current vs. altitude at 24V



14. PROTECTION FEATURES

Output protection	Electronically protected against overload, no-load and short-circuits *)	
Output over-voltage protection	typ. 16.5Vdc max. 16.8Vdc	in case of an internal power supply defect, a redundant circuit limits the maximum output voltage. The output shuts down and automatically attempts to restart.
Reverse input polarity protection	Included	unit does not start when input voltage is reversed
Output over-current protection	electronically limited *)	see Fig. 5-1
Degree of protection	IP 20	EN/IEC 60529
Penetration protection	> 3.5mm	e.g. screws, small parts
Over-temperature protection	yes	output shut-down with automatic restart
Input transient protection	MOV	Metal Oxide Varistor
Internal input fuse	T10A H.B.C.	not user replaceable

*) In case of a protection event, audible noise may occur.

Oct 2009 / Rev. 1.3 DS-CD5.121-EN

All parameters are specified at 12V, 8A, 24Vdc input voltage, 25°C ambient and after a 5 minutes run-in time unless otherwise noted.

15. SAFETY FEATURES

Input / output separation *)	SELV PELV	IEC/EN 60950-1 IEC/EN 60204-1, EN 50178, IEC 62103, IEC 60364-4-41
Class of protection	III	PE (Protective Earth) connection not required. A connection of the "Chassis Ground" pin to earth is recommended for best EMI performance
Isolation resistance	> 5MΩ	input to output, 500Vdc
PE resistance	< 0.1Ω	between housing and Chassis Ground terminal
Touch current (leakage current)	The leakage current which is produced by the DC/DC converter itself depends on the input voltage ripple and need to be investigated in the final application. For a smooth DC input voltage, the produced leakage current is less than 100µA.	

*) Double or reinforced insulation

16. DIELECTRIC STRENGTH

The output voltage is floating and has no ohmic connection to the ground.

Type and factory tests are conducted by the manufacturer. Field tests may be conducted in the field using the appropriate test equipment which applies the voltage with a slow ramp (2s up and 2s down). Connect all phase-terminals together as well as all output poles before conducting the test. When testing, set the cut-off current settings to the value in the table below.

Fig. 16-1 Dielectric strength

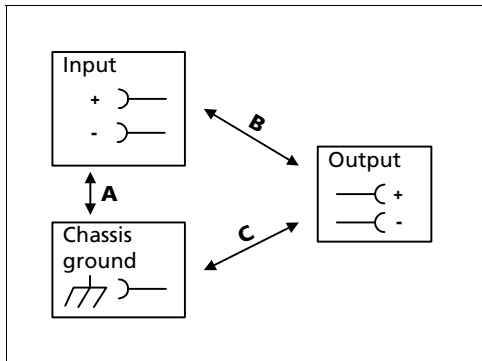

		A	B	C
Type test	60s	1500Vac	1500Vac	500Vac
Factory test	5s	1500Vac	1500Vac	500Vac
Field test	5s	1000Vac	1000Vac	500Vac
Cut-off current setting		> 30mA	> 30mA	> 12mA

To fulfill the PELV requirements according to EN60204-1 § 6.4.1, we recommend that either the + pole, the - pole or any other part of the output circuit shall be connected to the protective earth system. This helps to avoid situations in which a load starts unexpectedly or can not be switched off when unnoticed earth faults occur.

17. USED SUBSTANCES

The unit does not release any silicone and is suitable for the use in paint shops.

The unit conforms to the RoHS directive 2002/96/EC







Electrolytic capacitors included in this unit do not use electrolytes such as Quaternary Ammonium Salt Systems.

Plastic housings and other molded plastic materials are free of halogens, wires and cables are not PVC insulated.

The production material within our production does not include following toxic chemicals:

Polychlorized Biphenyl (PCB), Polychlorized Terphenyl (PCT), Pentachlorophenol (PCP), Polychlorinated naphthalene (PCN), Polybrom Biphenyl (PBB), Polybrom Biphenyl-oxyd (PBO), Polybrominated Diphenylether (PBDE), Polychlorinated Diphenylether (PCDE), Polydibromophenyl Oxyd (PBDO), Cadmium, Asbest, Mercury, Silicia

18. APPROVALS

IEC 60950-1		CB Scheme, Information Technology Equipment
UL 508		LISTED for use in U.S.A. (UL 508) and Canada (C22.2 No. 107-1-01) E-File: E198865 Industrial Control Equipment
ANSI / ISA 12.12.01-2007		RECOGNIZED E327416 recognized for use in U.S.A. (ANSI / ISA 12.12.01-2007) and Canada (C22.2 No. 213-M1987) Hazardous Location Class I Div 2 T4 Groups A,B,C,D
UL 60950-1		RECOGNIZED for the use in U.S.A. (UL 60950-1) and Canada (C22.2 No. 60950-1) E-File: E137006 Information Technology Equipment, Level 3
ANSI / ISA 12.12.01-2007		RECOGNIZED E246877 recognized for use in U.S.A. (ANSI / ISA 12.12.01-2007) and Canada (C22.2 No. 213-M1987) Hazardous Location Class I Div 2 T4 Groups A,B,C,D The unit is suitable for use in Class I Division 2 Groups A, B, C, D locations. Substitution of components may impair suitability for Class I Division 2 environment. Do not disconnect equipment unless power has been switched off. Wiring must be in accordance with Class I, Division 2 wiring methods of the National Electrical Code, NFPA 70, and in accordance with other local or national codes.
CSA 22.2 No107.1-01		CSA approval for Canada CAN/CSA C22.2 No 107-1; CAN/ CSA 60950-1-03; UL60950-1
Marine		GL (Germanischer Lloyd) classified and ABS (American Bureau for Shipping) PDA Environmental category: C, EMC2 Marine and offshore applications

19. FULFILLED STANDARDS

EN 61558-2-17	Safety of Power Transformers
EN/IEC 60204-1	Safety of Electrical Equipment of Machines
EN/IEC 61131-2	Programmable Controllers
EN 50178, IEC 62103	Electronic Equipment in Power Installations

20. PHYSICAL DIMENSIONS AND WEIGHT

Weight	425g / 0.94lb
DIN-Rail	Use 35mm DIN-rails according to EN 60715 or EN 50022 with a height of 7.5 or 15mm. The DIN-rail height must be added to the unit depth (102mm) to calculate the total required installation depth.
Installation Clearances	See chapter 2

Fig. 20-1 **Front view**

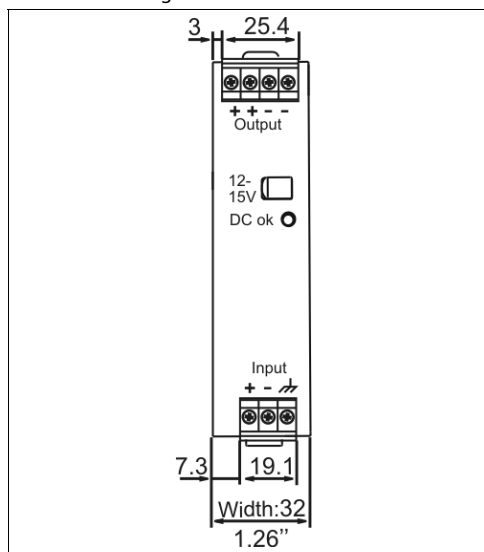
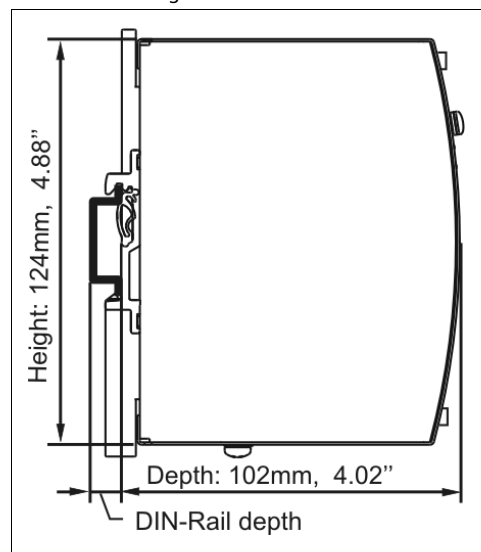

Fig. 20-2 **Side view**



21. ACCESSORIES

ZM1.WALL Wall mounting bracket

This bracket is used to mount specific Dimension units onto a flat surface without utilizing a DIN-Rail. The two aluminum brackets and the black plastic slider of the unit have to be removed, so that the two steel brackets can be mounted.

Fig. 21-1 ZM1.WALL Wall mounting bracket

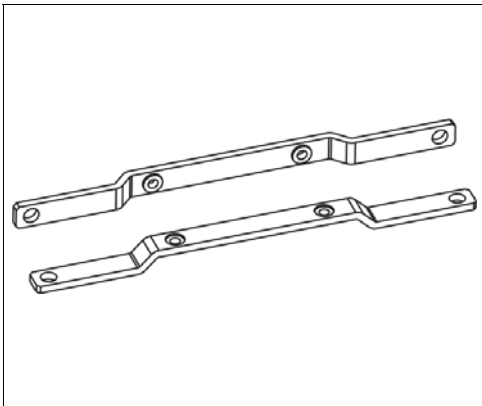
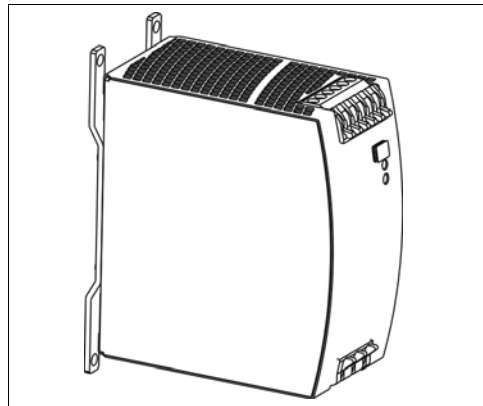

Fig. 21-2 Assembled wall mounting bracket *)



*) Picture of the DC/DC converter is for representation only

ZM11.SIDE Side mounting bracket

This bracket is used to mount Dimension units sideways with or without utilizing a DIN-Rail. The two aluminum brackets and the black plastic slider of the unit have to be detached, so that the steel brackets can be mounted. For sideway DIN-rail mounting, the removed aluminum brackets and the black plastic slider need to be mounted on the steel bracket.

Fig. 21-3
ZM11.SIDE Side mounting bracket *)

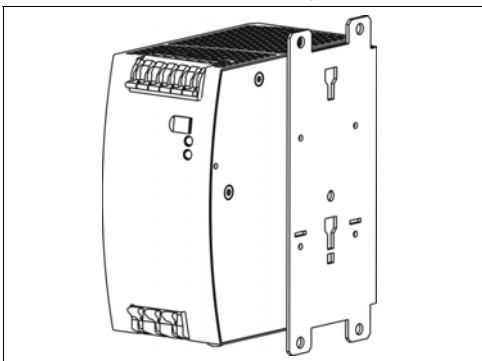

*) Picture of the DC/DC converter is for representation only

Fig. 21-4
Side mounting with DIN-rail brackets *)

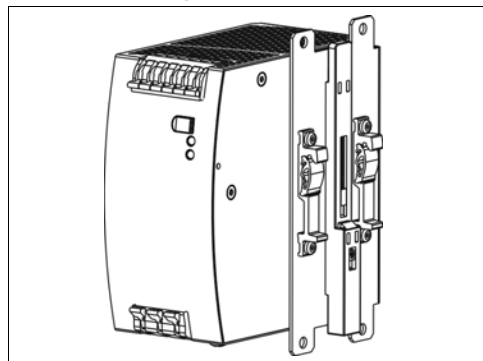

22. APPLICATION NOTES

22.1. PEAK CURRENT CAPABILITY

Solenoids, contactors and pneumatic modules often have a steady state coil and a pick-up coil. The inrush current demand of the pick-up coil is several times higher than the steady-state current and usually exceeds the nominal output current (including the PowerBoost). The same situation applies, when starting a capacitive load.

Branch circuits are often protected with circuit breakers or fuses. In case of a short or an overload in the branch circuit, the fuse needs a certain amount of over-current to trip or to blow. The peak current capability ensures the safe operation of subsequent circuit breakers.

Assuming the input voltage is turned on before such an event, the built-in large sized output capacitors inside the DC/DC converter can deliver extra current. Discharging this capacitor causes a voltage dip on the output. The following two examples show typical voltage dips:

Fig. 22-1 Peak loading with 2x the nominal current for 50ms, typ.

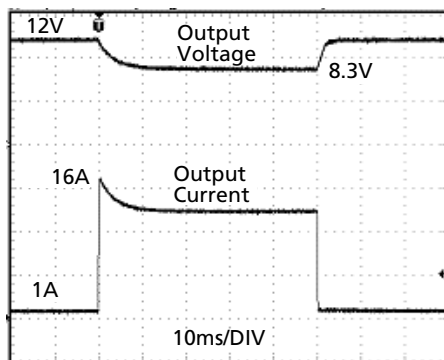

Peak load 16A (resistive load) for 50ms
Output voltage dips from 12V to 8.3V.

Fig. 22-2 Peak loading with 5x the nominal current for 5ms, typ.

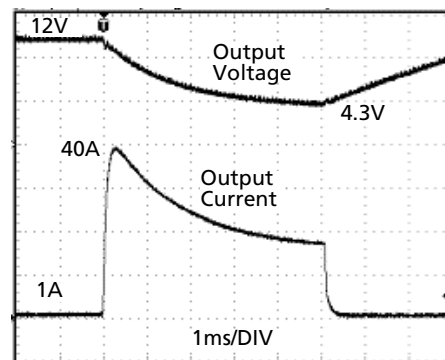

Peak load 40A (resistive load) for 5ms
Output voltage dips from 12V to 4.3V.

22.2. BACK-FEEDING LOADS

Loads such as decelerating motors and inductors can feed voltage back to the DC/DC converter. This feature is also called return voltage immunity or resistance against Back- E.M.F. (E lectro M agnetic F orce).

This DC/DC converter is resistant and does not show malfunctioning when a load feeds back voltage to the DC/DC converter. It does not matter, whether the DC/DC converter is on or off.

The maximum allowed feed-back-voltage is 16Vdc. The absorbing energy can be calculated according to the built-in large sized output capacitance which is specified in chapter 5.

22.3. INDUCTIVE AND CAPACITIVE LOADS

The unit is designed to supply any kind of loads, including unlimited capacitive and inductive loads.

22.4. CHARGING OF BATTERIES

The DC/DC converter can be used to charge lead-acid or maintenance free 12V VRLA batteries.

Instructions for charging batteries:

- a) Ensure that the ambient temperature of the DC/DC converter is below 45°C
- b) Do not use DC/DC converters in mounting orientations other than the standard mounting orientation (input terminals on the bottom and output terminals on top of the unit).
- c) Set output voltage (measured at no load and at the battery end of the cable) very precisely to the end-of-charge voltage.

End-of-charge voltage	13.9V	13.75V	13.6V	13.4V
Battery temperature	10°C	20°C	30°C	40°C

- d) Use a 10A circuit breaker (or blocking diode) between the DC/DC converter and the battery.
- e) Ensure that the output current of the DC/DC converter is below the allowed charging current of the battery.
- f) The return current to the DC/DC converter (battery discharge current) is typ. 15mA when the DC/DC converter is switched off (except in case a blocking diode is utilized).

22.5. EXTERNAL INPUT PROTECTION

The unit is tested and approved for branch circuits up to 50A. An external protection is only required, if the supplying branch has an ampacity greater than this. Check also local codes and local requirements. In some countries local regulations might apply.

If an external fuse is necessary or utilized, minimum requirements need to be considered to avoid nuisance tripping of the circuit breaker. A minimum value of 10A B- or 8A C-Characteristic breaker should be used.

22.6. REQUIREMENTS FOR THE SUPPLYING SOURCE

In certain circumstances, the input filter of the DC/DC converter can show a resonant effect which is caused by the supplying network. Especially when additional external input filters are utilized, a superimposed AC voltage can be generated on the input terminals of the DC/DC converter which might cause a malfunction of the unit. Therefore, additional input filters are not recommended. To avoid the resonant effects, the minimal resistance of the supplying network which depends on the inductance of the input network, shall be above the boundary curve in Fig. 22-3.

Fig. 22-3 External input filter requirements to avoid filter instabilities

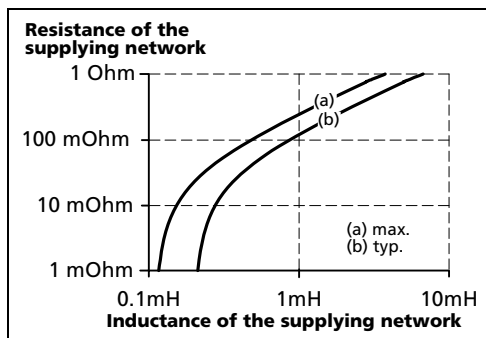

22.7. PARALLEL USE TO INCREASE OUTPUT POWER

The DC/DC-converter can be paralleled to increase the output power. There are no feature included which balances the load current between the DC/DC-converters. Therefore some restrictions and limitations apply. The DC/DC-converter with the higher adjusted output voltage draws current until it goes into current limitation. This means no harm or switch-off to this DC/DC-converter as long as the ambient temperature stays below 45°C. The CD5.121 can also be paralleled with power supplies from the QS10.121 from the DIMENSION QS-series. For other power supplies consult PULS.

The output voltages of all DC/DC-converters shall be adjusted to the same value ($\pm 100\text{mV}$) at full load. A fuse or diode on the output of each unit is only required if more than three units are connected in parallel. This avoid that more than 2 times of the nominal output current can flow backwards into the DC/DC converter in case the output stage of one DC/DC converter has a defect. If a fuse (or circuit breaker) is used, choose one with approximately 150% of the rated output current of one DC/DC-converter. Keep an installation clearance of 15mm (left / right) between two DC/DC-converters and avoid installing the DC/DC-converters on top of each other. Do not use DC/DC-converters in parallel in mounting orientations other than the standard mounting orientation (input terminals on the bottom and output terminals on top of the unit).

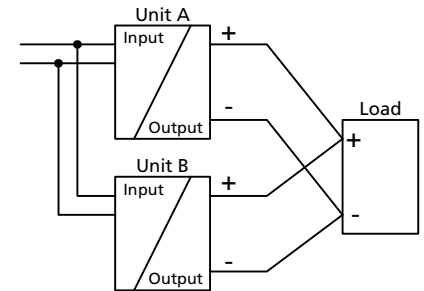

22.8. PARALLEL USE FOR REDUNDANCY

The DC/DC converters can be paralleled for 1+1 redundancy to gain higher system availability. Redundant systems require a certain amount of extra power to support the load in case one DC/DC converter fails. The simplest way is to put two DC/DC converters in parallel. This is called a 1+1 redundancy. In case one DC/DC converter fails, the other one is automatically able to support the load current without any interruption. Redundant systems for a higher power demand are usually built in an N+1 method. E.g. six DC/DC converters, each rated for 8A are paralleled to build a 40A redundant system.

Furthermore, 1+1 redundant systems can be built by using a DC/DC converter powered from a battery and a power supply with AC input.

Please note: This simple way to build a redundant system does not cover failures such as an internal short circuit in the secondary side of the DC/DC-converter. In such a case, the defect unit becomes a load for the other DC/DC-converters and the output voltage can not be maintained any more. This can only be avoided by utilizing decoupling diodes which are included in the decoupling module YR2.DIODE.

Recommendations for building redundant power systems:

- Use separate input fuses for each DC/DC-converter.
- Monitor the individual DC/DC-converter units.
- 1+1 Redundancy is allowed up to an ambient temperature of 60°C
N+1 Redundancy is allowed up to an ambient temperature of 45°C
- It is desirable to set the output voltages of all units to the same value ($\pm 100\text{mV}$) or leave it at the factory setting.

22.9. DAISY CHAINING OF OUTPUTS

Daisy chaining (jumping from one DC/DC-converter output to the next) is allowed as long as the average output current through one terminal pin does not exceed 25A. If the current is higher, use a separate distribution terminal block.

Fig. 22-4 Daisy chaining of outputs

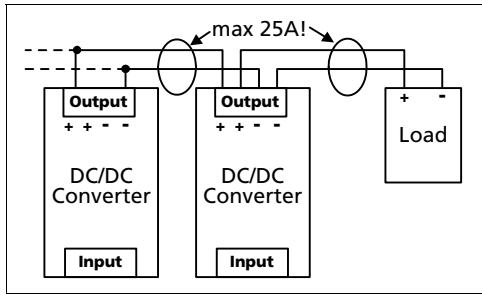
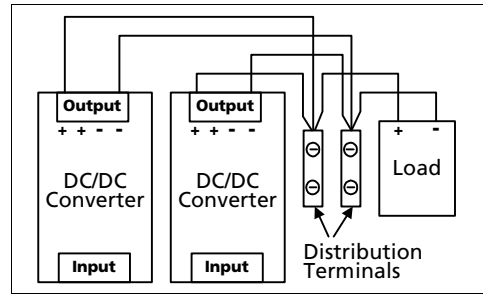
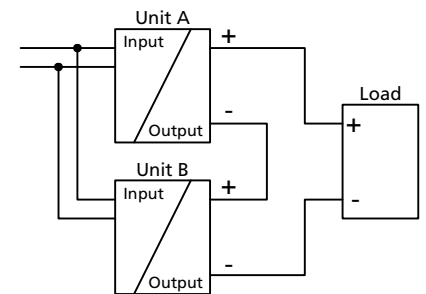

Fig. 22-5 Using distribution terminals



22.10. SERIES OPERATION

DC/DC converters of the exact same type can be connected in series for higher output voltages. It is possible to connect as many units in series as needed, providing the sum of the output voltage does not exceed 150Vdc. Voltages with a potential above 60Vdc are not SELV any more and can be dangerous. Such voltages must be installed with a protection against touching. Earthing of the output is required when the sum of the output voltage is above 60Vdc. Avoid return voltage (e.g. from a decelerating motor or battery) which is applied to the output terminals. Keep an installation clearance of 15mm (left / right) between two DC/DC-converters and avoid installing the DC/DC-converters on top of each other. Do not use DC/DC-converters in series in mounting orientations other than the standard mounting orientation (input terminals on the bottom and output terminals on top of the unit).



22.11. USE IN A TIGHTLY SEALED ENCLOSURE

When the DC/DC-converter is installed in a tightly sealed enclosure, the temperature inside the enclosure will be higher than outside. In such situations, the inside temperature defines the ambient temperature for the DC/DC-converter.

The following measurement results can be used as a reference to estimate the temperature rise inside the enclosure.

The DC/DC-converter is placed in the middle of the box, no other heat producing items are inside the box

Enclosure:	Rittal Typ IP66 Box PK 9516 100, plastic, 110x180x165mm
Load:	12V, 6.4A; (=80%) load is placed outside the box
Input:	24Vdc
Temperature inside enclosure:	48.0°C (in the middle of the right side of the DC/DC converter with a distance of 2cm)
Temperature outside enclosure:	22.6°C
Temperature rise:	25.4K

22.12. MOUNTING ORIENTATIONS

Mounting orientations other than input terminals on the bottom and output on the top require a reduction in continuous output power or a limitation in the max. allowed ambient temperature. The amount of reduction influences the lifetime expectancy of the DC/DC converter. Therefore, two different derating curves for continuous operation can be found below:

Curve A1 Recommended output current.

Curve A2 Max allowed output current (results in approximately half the lifetime expectancy of A1).

Fig. 22-6
Mounting Orientation A
(Standard orientation)

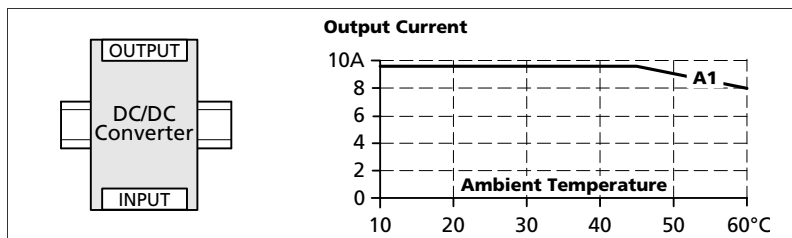

Fig. 22-7
Mounting Orientation B
(Upside down)

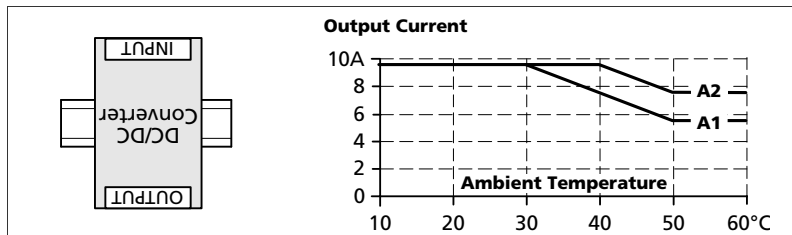

Fig. 22-8
Mounting Orientation C
(Table-top mounting)

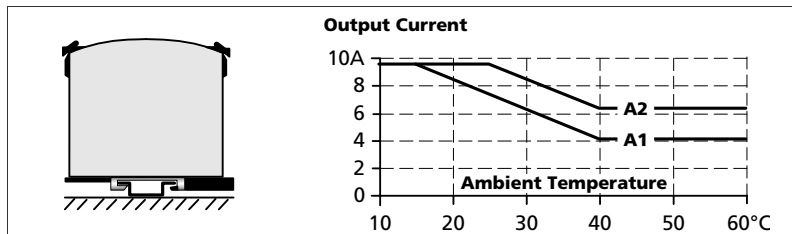

Fig. 22-9
Mounting Orientation D
(Horizontal cw)

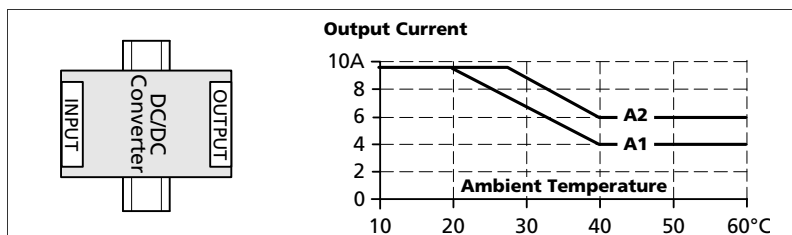

Fig. 22-10
Mounting Orientation E
(Horizontal ccw)

